

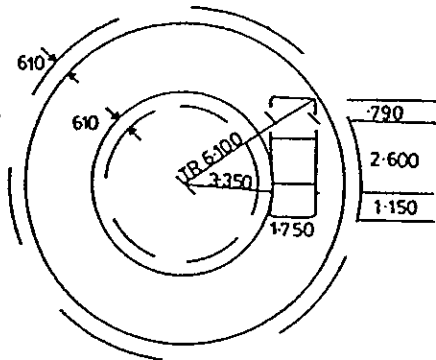

# **APPENDIX I**

## **Carparking Standards**

---



90 PERCENTILE DESIGN CAR

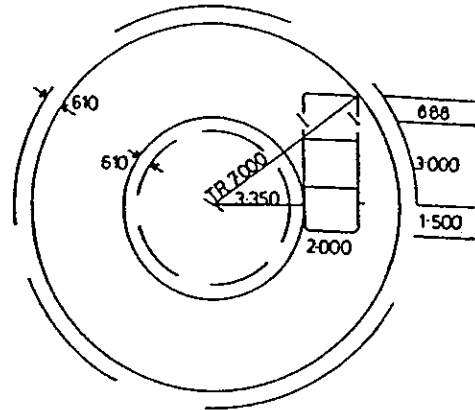

99 PERCENTILE DESIGN CAR

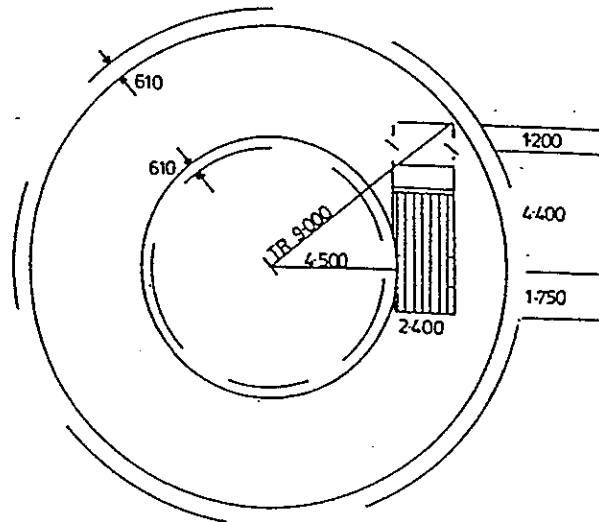

90 PERCENTILE DESIGN TWO AXLED TRUCK

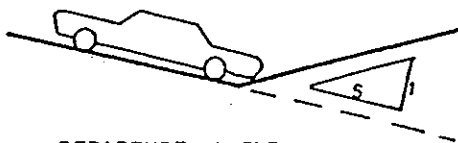

DEPARTURE ANGLE  
1 in 5 max

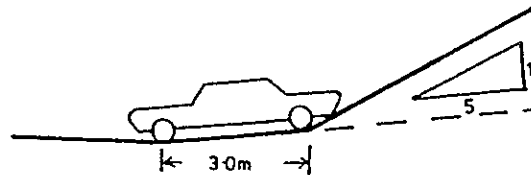

ACCESS DRIVE GRADE CHANGE  
1 in 5 max at 3.0m in from kerb  
or edge of carriageway if no kerb.

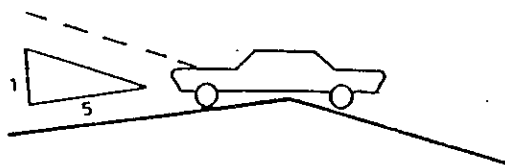

BREAKOVER ANGLE  
1 in 5 max

NOT TO SCALE

Continued Over

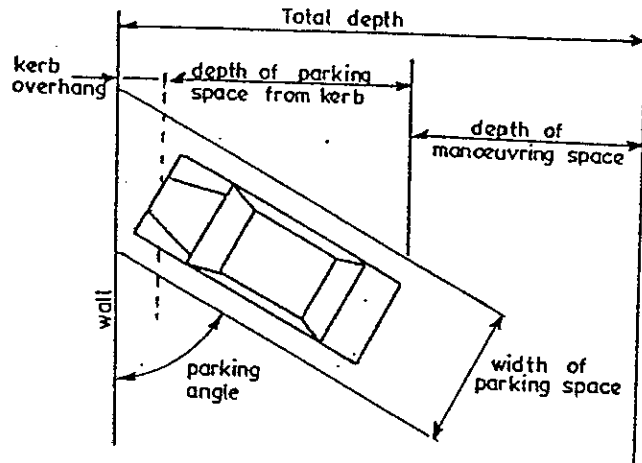

Parking angle	Width of parking space	Kerb overhang	Depth of parking space from kerb	Depth of manoeuvring space	Total depth
90°	2.4m	0.61m	4.3m	8.2m	13.1m
	2.6m			7.3m	12.2m
	2.7m			6.4m	11.3m
75°	2.4m	0.61m	4.6m	5.5m	10.6m
	2.6m			4.8m	10.1m
	2.7m			4.3m	9.4m
60°	2.4m	0.61m	4.6m	3.9m	10.7m
	2.6m			3.7m	8.8m
	2.7m			3.7m	8.8m
45°	2.4m	0.45m	4.4m	3.7m	8.5m
	2.6m				
	2.7m				
30°	2.4m	0.30m	3.7m	3.7m	7.6m
	2.6m				
	2.7m				
0°	2.4m	0.30m	2.1m	3.7m	6.1m
	2.6m				
	2.7m				

Continued